

NOTES:

1. WEIGHT (DRY): 15-LBS
2. MATERIALS:
 - A. DEBRIS SHIELD: PERFORATED STAINLESS STEEL ALLOY WITH 51% OPEN AREA
 - B. BYPASS HOOD: ALUMINUM ALLOY, 0.062 THK
 - C. SUPPORT HARDWARE: CRES 300 SERIES
3. PERFORMANCE CHARACTERISTICS:
 - A. PERFORATED DEBRIS SHIELD
FLOW RATE: 1440 GPM (3.2 CFS)
 - B. DEBRIS CAPACITY: 0.96 CU-FT
 - C. BYPASS FLOW RATE: 109 GPM (0.24 CFS)
4. ADJUSTMENT RANGE:
 - A. MINIMUM TRENCH WIDTH: 6.0-IN
 - B. MAXIMUM TRENCH WIDTH: 10.0-IN
 - C. MINIMUM TRENCH DRAIN DEPTH: 10" BELOW BOTTOM OF GRATE(S)
5. TYPICAL INSTALLATION: CAREFULLY REMOVE THE TRENCH DRAIN GRATE(S) AND PLACE THE FILTER UNIT DIRECTLY ON THE DRAIN FLOOR. VERIFY THAT THE BYPASS HOOD IS AT OR BELOW THE GRATE SUPPORT LEDGE SO NOT TO INTERFERE WITH THE RE-INSTALLED GRATE(S). WITH THE TRENCH DRAIN FILTER APPROXIMATELY CENTERED IN THE DRAIN TROUGH, MARK, DRILL AND SECURE UNIT IN PLACE WITH THE STRIKE ANCHORS PROVIDED
6. MAINTENANCE: SYSTEM IS DESIGNED TO BE EASILY OPENED FOR CLEANING OF DEBRIS AND REMOVAL OF FILTER BOOM. USE STANDARD VACTOR HOSE OR SIMPLE SHOVEL AND RAKE TO REMOVE DEBRIS. DISPOSE OF FILTER BOOM AND DEBRIS ACCORDING TO LOCAL ORDINANCES/REGULATIONS. PRESSURE WASH DEBRIS SHIELD AS NEEDED AND INSERT NEW FILTER BOOM. USE ONLY FABCO REPLACEABLE FILTER BOOM, P/N: 10063-1-"SEE TABLE".

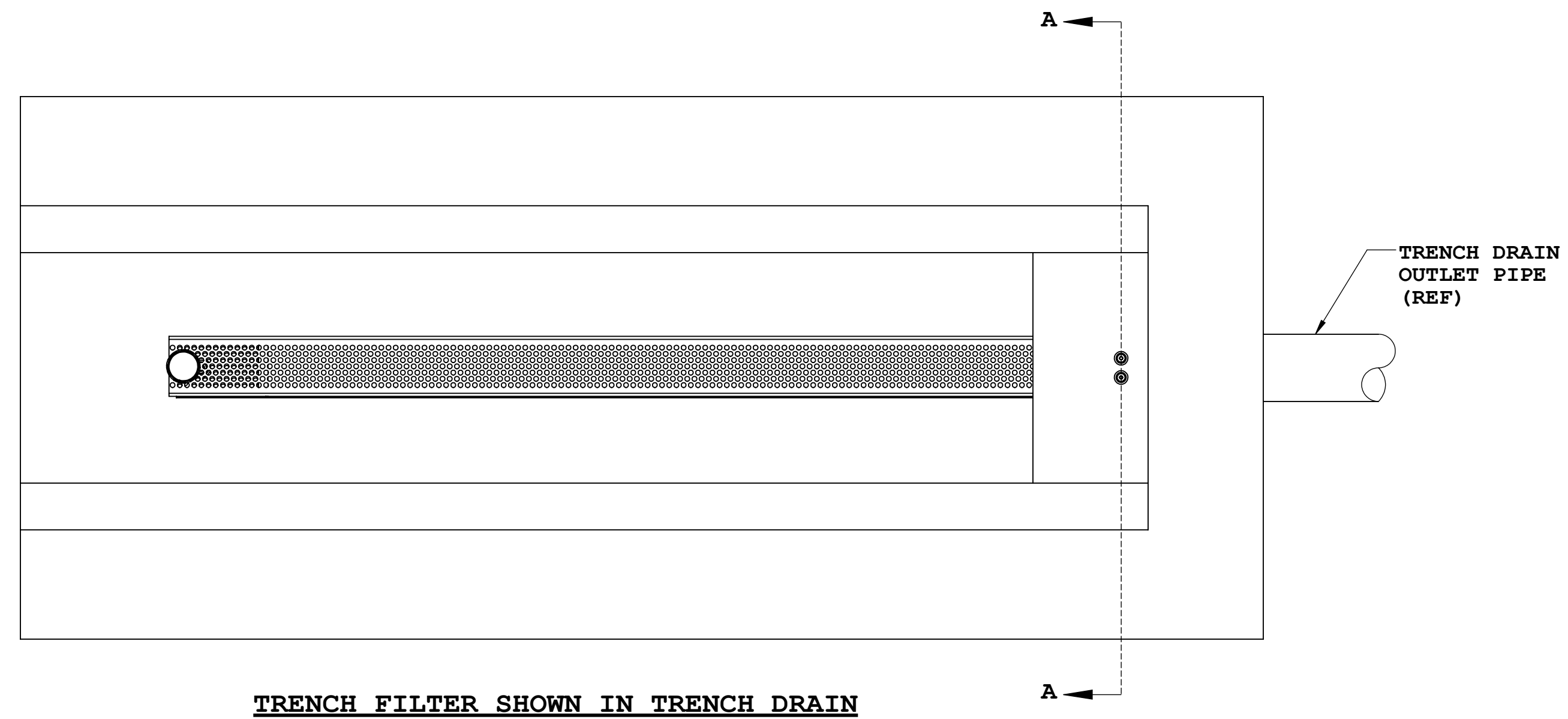

TRENCH FILTER SHOWN IN TRENCH DRAIN

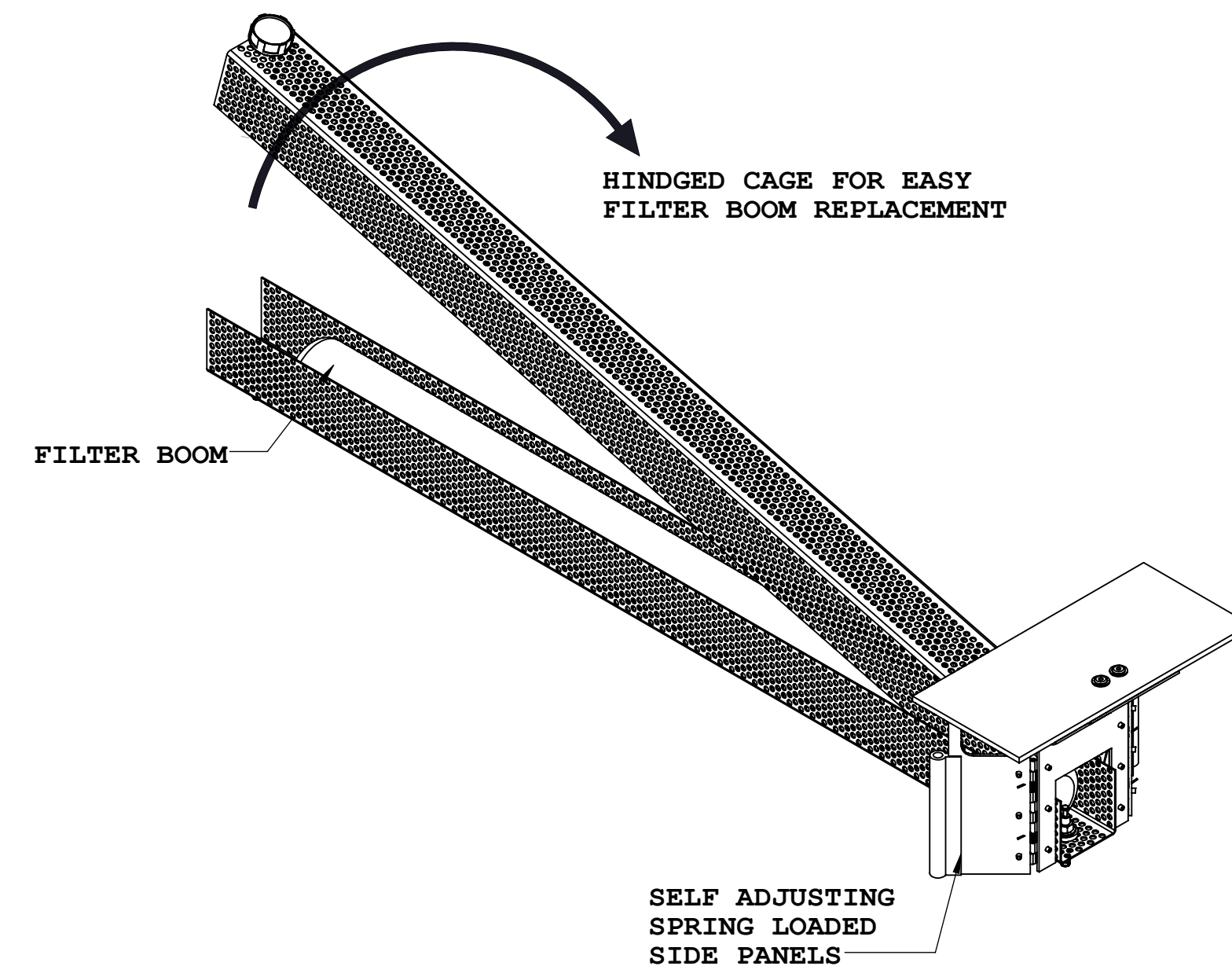

REPLACEABLE FILTRATION BOOMS	
10063-1-710	OIL BOOM
10063-1-720	NUTRIENT BOOM
10063-1-730	BACTERIA BOOM

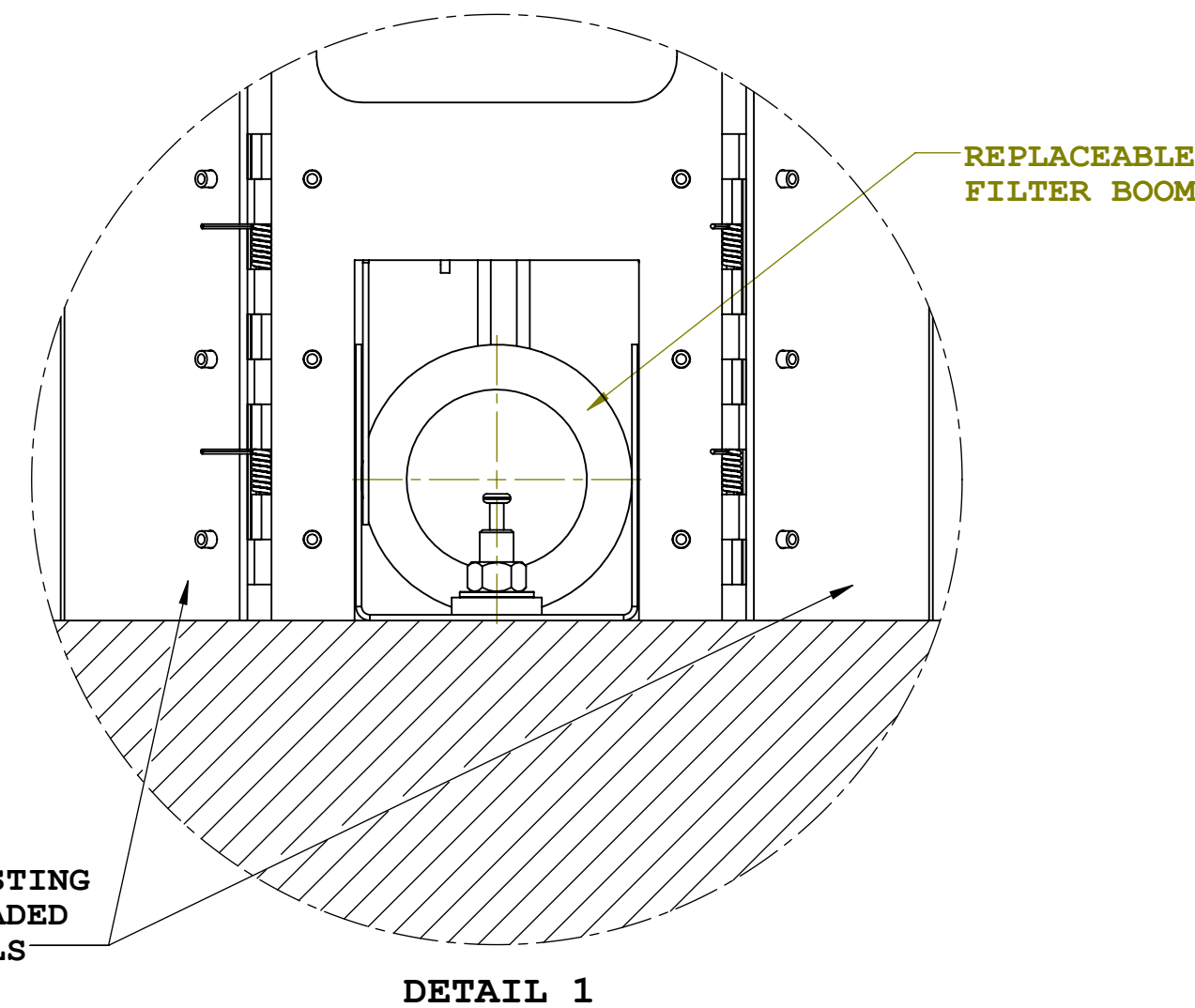
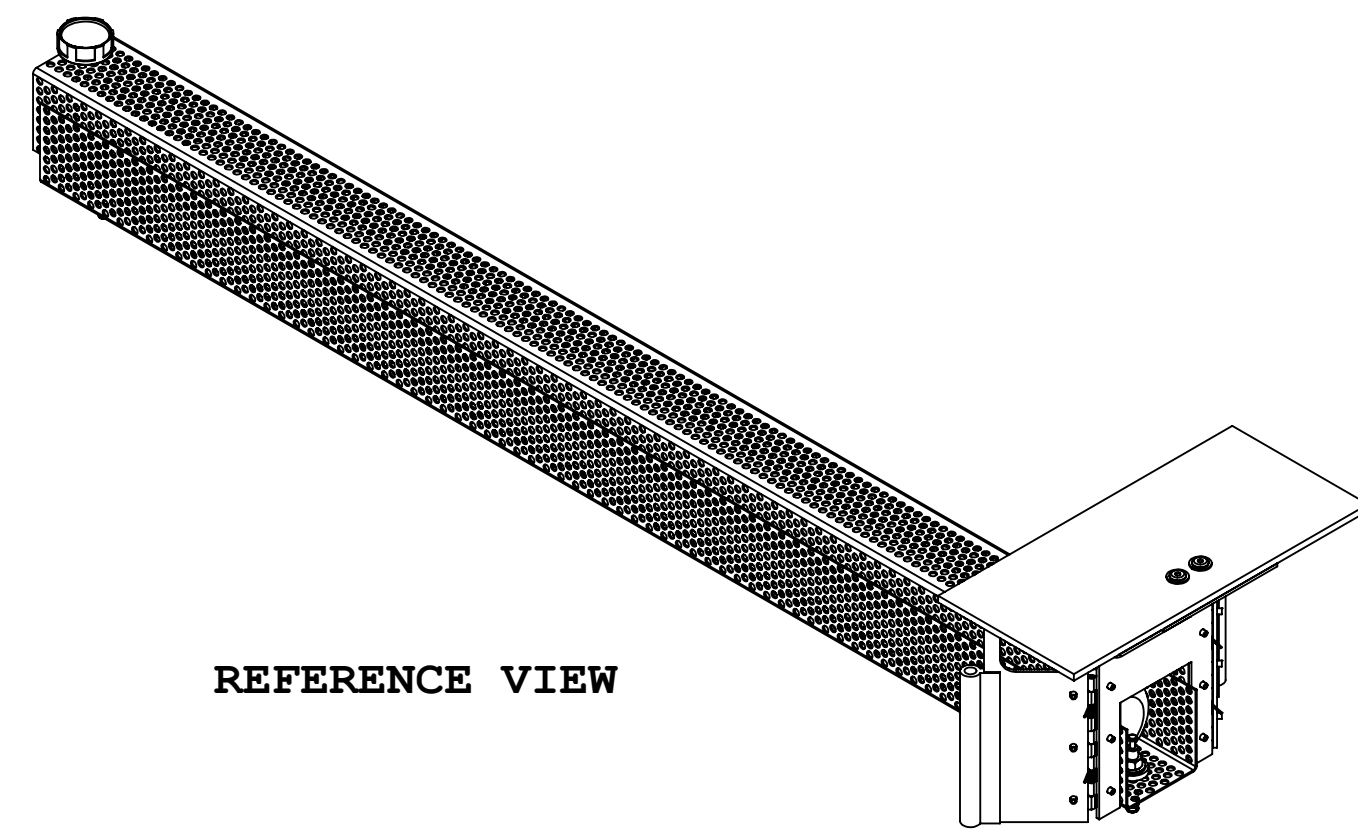
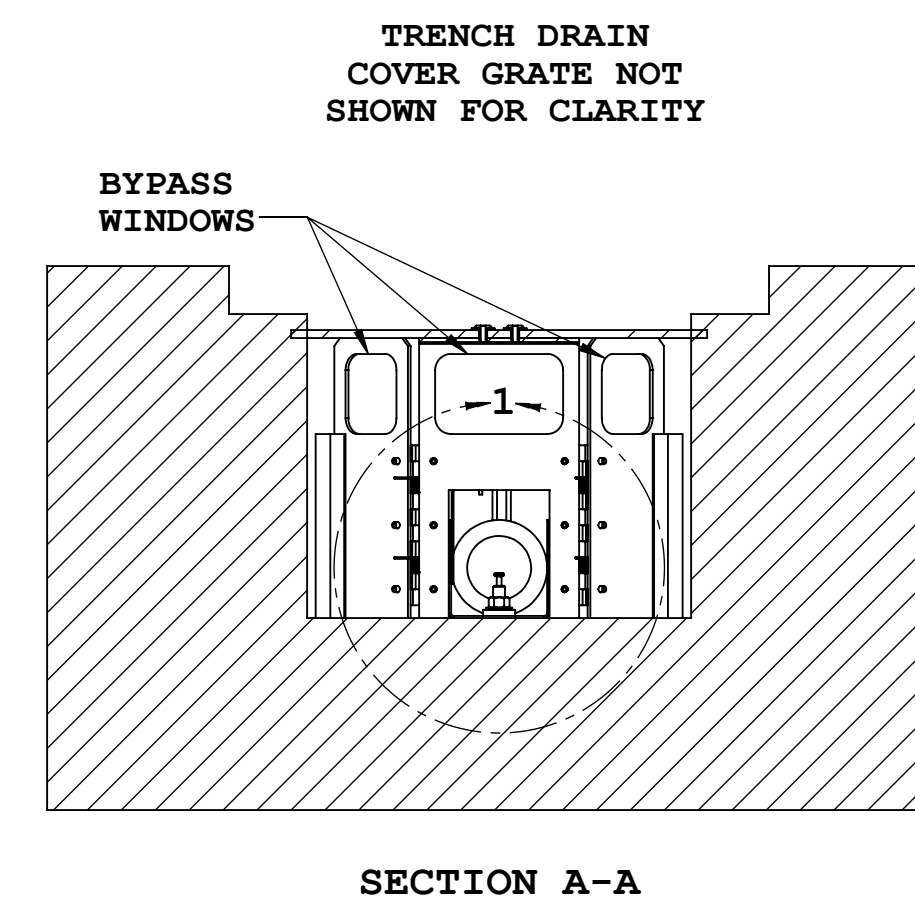
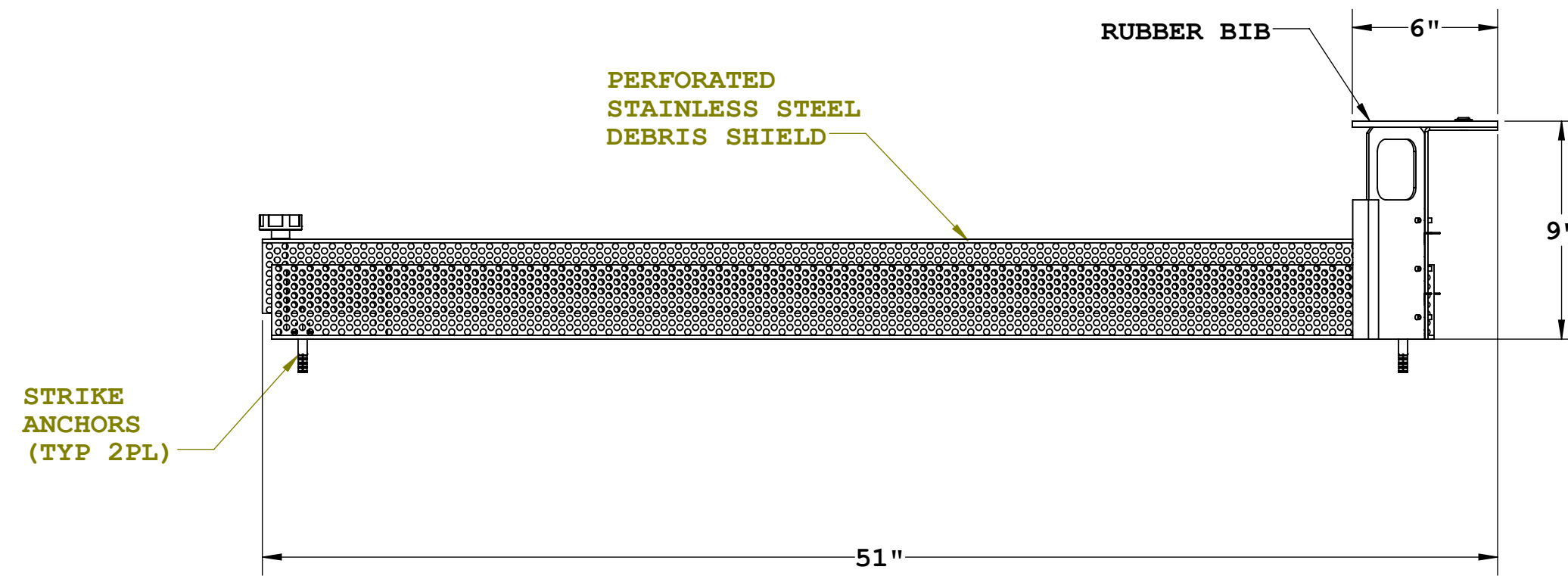

UNLESS OTHERWISE SPECIFIED REMOVE ALL BURRS BREAK SHARP EDGES .002 - .020 FILLETS .020 MAX DIMENSIONS ARE IN INCHES AND INCLUDE CHEMICALLY APPLIED OR PLATED FINISHES	TOLERANCES: DEC .00 ± .01 DEC .000 ± .005 FRACT ± 1/16 ANGLE ± 2°	APPROVALS MS 11/25/14 CHKR JP 11/25/14 ENGR ARVD	DATE
MATERIAL SEE NOTES	FABCO INDUSTRIES, INC. 66 CENTRAL AVENUE FARMINGDALE, NY 11735	TITLE: TRENCH DRAIN FILTER 6"-10" CLEAR WIDTH	
MODEL LINK 10063-1-000	WWW.FABCO-INDUSTRIES.COM	SIZE DWG. NO. D 10063-1-000 REV E	
SCALE: 1:6 WEIGHT:			SHEET 1 OF 1

