

GENERAL INSTALLATION:
 ADJUST THE TURNBUCKLE DOWN TO GIVE THE SMALLEST RING DIAMETER AND LOCATE THE EXPANSION RING INTO THE HARCO STRUCTURE MINIMUM OF 6-IN DOWN FROM THE TOP OPENING AS SHOWN. BEGIN OPENING THE TURNBUCKLE UNTIL THE EXPANSION RING IS SELF SUPPORTING, THEN VERIFY THE RING IS LEVEL AND PLUMB TO THE HARCO STRUCTURE. USING A CALIBRATED TORQUE WRENCH, CONTINUE TO OPEN THE TURNBUCKLE TO 10 FT-LB (+/- 0.5 FT-LB) TORQUE. DO NOT OVER TIGHTEN. INSTALL THE STORMSACK ASSEMBLY DIRECTLY ON THE SUPPORT RING.

NOTES FOR 10135-3S-500 STORMSOK ASSEMBLY AND 10101-3-000 EXPANSION RING:

- WEIGHT (EMPTY): 25 LB MAX
- MATERIAL:
 - A) SUPPORT FLANGE: ALUMINUM ALLOY PLATE, 5000 SERIES
 - B) STORMSOK: WOVEN POLYPROPYLENE GEOTEXTILE
 - C) APPARENT OPENING SIZE (AOS): 20 US SIEVE (840 MICRONS)
 - D) EXPANSION RING: ALUMINUM ALLOY CHANNEL, 6000 SERIES
 - E) HARDWARE: STAINLESS STEEL
- PERFORMANCE CHARACTERISTICS (TYP):
 - A) DEBRIS CAPACITY: 0.71 CU-FT
 - B) FILTERED FLOW RATE: 670 GPM (1.5 CFS)
 - C) BYPASS FLOW RATE: 445 GPM (1.0 CFS)
- DESIGNED TO FIT HARCO CASTING, P/N: 1899CGS AND ALL ASSOCIATED TRANSITION PLATES
- RECOMMENDED MINIMUM VAULT DEPTH: 2-IN BELOW STORMSOK
- USE WITH FABCO REPLACEABLE STORMSOK, P/N: 10135-3S-102
- DEEP (22" LONG) STORMSOK IS AVAILABLE ON REQUEST
- REPLACEABLE OIL BOOM AVAILABLE ON REQUEST

DESIGNED FOR USE WITH THE FOLLOWING HARCO CASTINGS

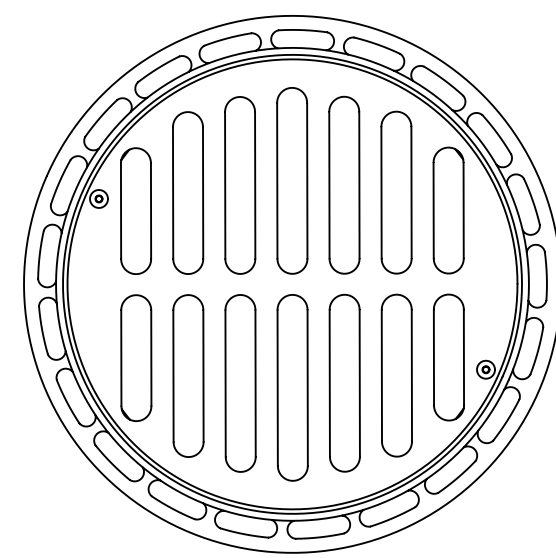

STORMSOK FITS ROUND HARCO 18" GRATE

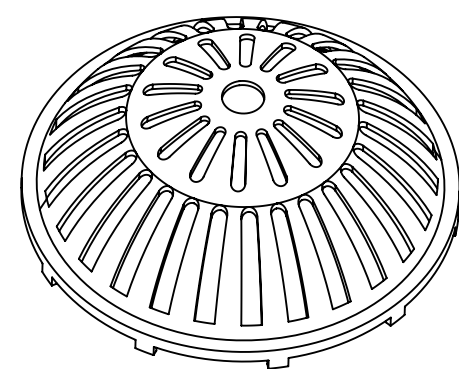

STORMSOK FITS DOME HARCO 18" GRATE

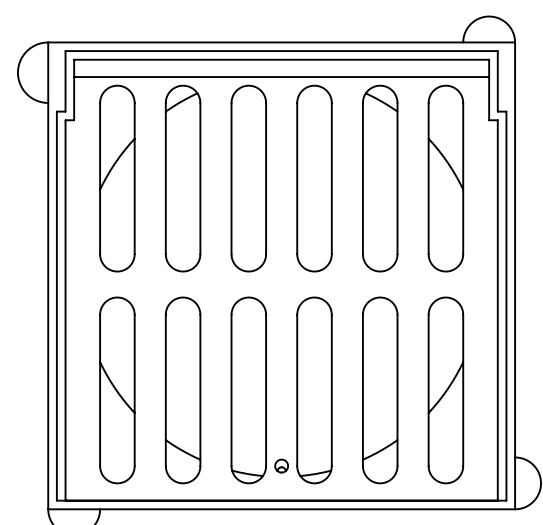

STORMSOK FITS SQUARE HARCO 18" GRATE

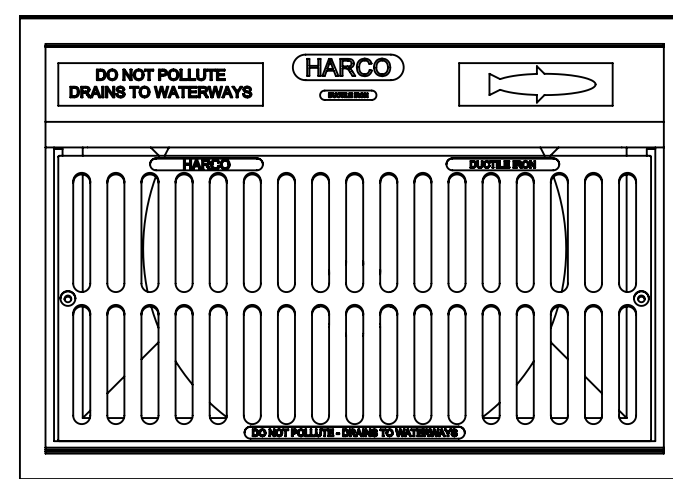

STORMSOK FITS 2 X 2 HARCO 18" CURB INLET

PROPRIETARY AND CONFIDENTIAL
 THIS DOCUMENT IS THE PROPERTY OF FABCO INDUSTRIES AND IS CONVEYED WITH THE EXPRESS CONDITION THAT IT AND THE INFORMATION CONTAINED IN IT ARE NOT TO BE USED, DISCLOSED, OR REPRODUCED IN WHOLE OR IN PART, FOR ANY PURPOSE WITHOUT THE EXPRESS WRITTEN CONSENT OF FABCO INDUSTRIES; AND THAT NO RIGHT IS GRANTED TO DISCLOSE OR SO USE ANY INFORMATION CONTAINED IN SAID DOCUMENT.

UNLESS OTHERWISE SPECIFIED REMOVE ALL BURRS BREAK SHARP EDGES .002 - .020 FILLETS .020 MAX DIMENSIONS ARE IN INCHES AND INCLUDE CHEMICALLY APPLIED OR PLATED FINISHES	TOLERANCES: DEC .00 ± .01 DEC .000 ± .005 FRACT ± 1/16 ANGLE ± 2°	APPROVAL DWN MS CHKR JP ENGR JP ARVD	DATE 1/12/15 1/12/15
PROJECT	SEE NOTES	FABCO INDUSTRIES, INC. 66 CENTRAL AVENUE FARMINGDALE, NY 11735 WWW.FABCO-INDUSTRIES.COM	
MATERIAL	10135-3-000	TITLE: STORMSOK AND EXPANSION RING FOR 18" ROUND HARCO STORM DRAIN	
MODEL LINK		SIZE: D	DWG. NO. 10135-3S-000
		SCALE: NONE	REV C
			SHEET 1 OF 1

