

THIS DOCUMENT IS THE PROPERTY OF FABCO INDUSTRIES AND IS CONVEYED WITH THE EXPRESS CONDITION THAT IT AND THE INFORMATION CONTAINED IN IT ARE NOT TO BE USED, DISCLOSED, OR REPRODUCED IN WHOLE OR IN PART FOR ANY PURPOSE WITHOUT THE EXPRESS WRITTEN CONSENT OF FABCO INDUSTRIES, AND THAT NO RIGHT IS GRANTED TO DISCLOSE OR SO USE ANY INFORMATION CONTAINED IN SAID DOCUMENT.

NOTES:

- WEIGHT (EMPTY): 30 LB MAX, NO CARTRIDGES
- MATERIAL:
 - ADJUSTABLE FLANGE AND DEFLECTOR: ALUMINUM ALLOY 6063-T6
 - BASIN (PLASTIC): POLYPROPYLENE POLYETHYLENE COPOLYMER
 - CORNER FILL: ALUMINUM ALLOY: 5052-H32
 - SUPPORT HARDWARE: CRES 300 SERIES
- PERFORMANCE CHARACTERISTICS (TYP):
 - DEBRIS CAPACITY: 4.1 CU-FT
 - FILTERED FLOW RATE (CLEAN STANDARD CARTRIDGE): 230 GPM (.52 CFS)
 - PRIMARY BYPASS FLOW RATE: 1636 GPM (3.6 CFS)
 - SECONDARY BYPASS FLOW RATE: 328 GPM (.73 CFS)
 - TOTAL BYPASS FLOW RATE: 1964 GPM (4.4 CFS)
- CLEAR OPENING RANGE (0.5 INCH INCREMENTS):
 - MINIMUM SIZE: 19.0 X 37.0
 - MAXIMUM SIZE: 24.0 X 42.0
- RECOMMENDED MINIMUM VAULT DEPTH 2-IN BELOW CARTRIDGE
- TYPICAL INSTALLATION: REMOVE STORM GRATE, MEASURE CATCH BASIN FRAME CLEAR OPENING AND ADJUST FLANGES TO REST ON GRATE SUPPORT LEDGE. INSTALL STORMBASIN INSERT AND VERIFY THE ADJUSTABLE FLANGES ARE SECURELY RESTING ON THE GRATE SUPPORT LEDGES. INSTALL CORNER FILLER PIECES. REINSTALL THE STORM GRATE DIRECTLY ON THE STORMBASIN SUPPORT FLANGES.
- USE ONLY WITH FABCO REPLACEABLE MEDIA CARTRIDGES.

DWS NO.		REV. C		1	
REVISIONS					
REV	DESCRIPTION	DATE	APPROVED		
C	9730-3C-000C	5/18/11			

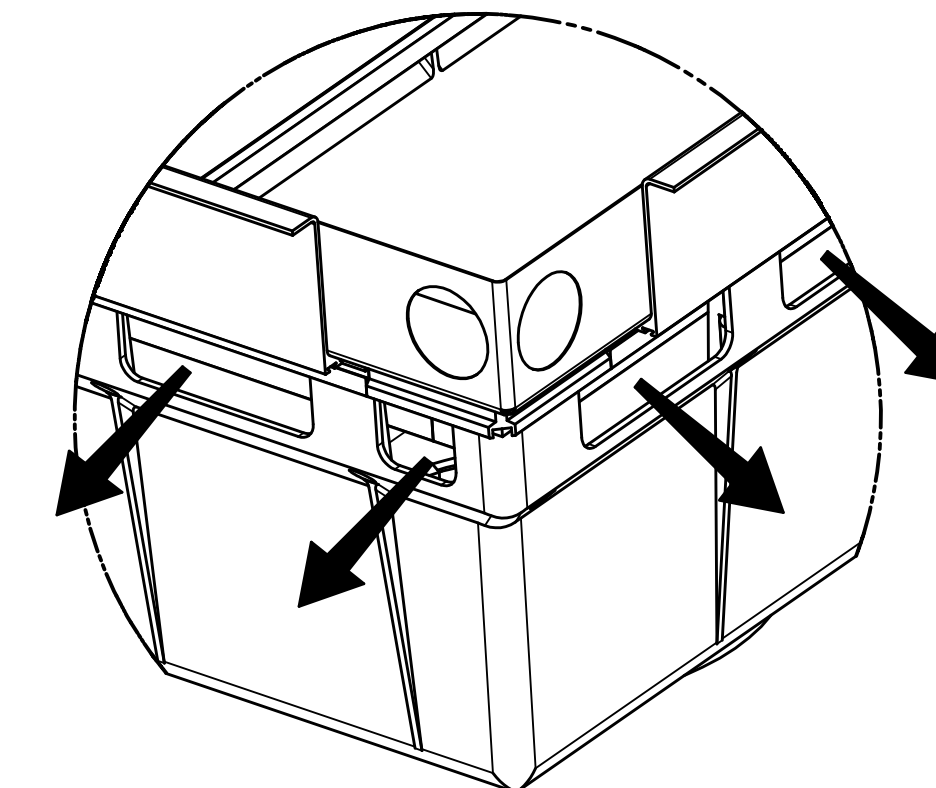
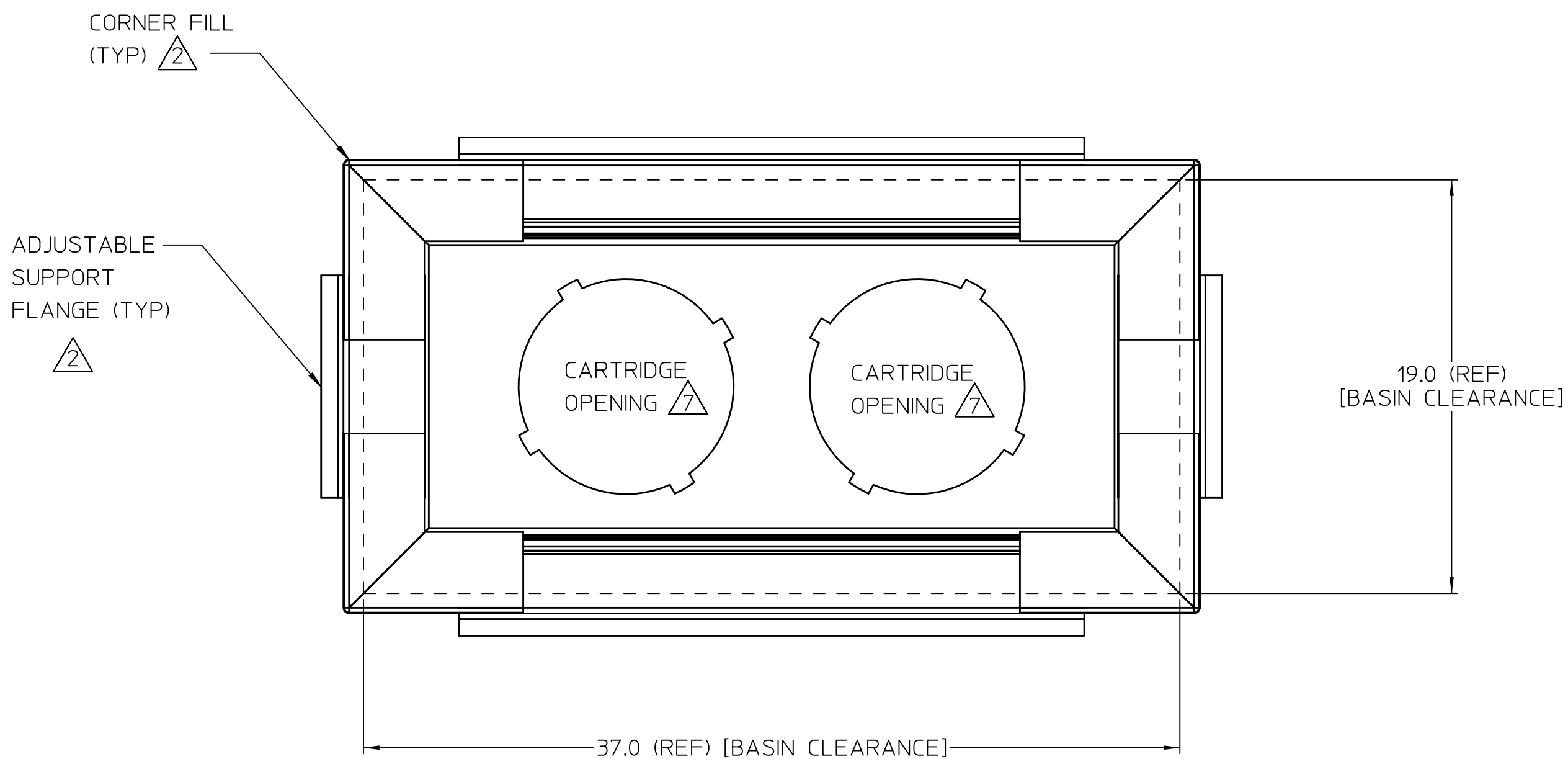

PROTECTED BYPASS, TYPICAL
(NOT TO SCALE)

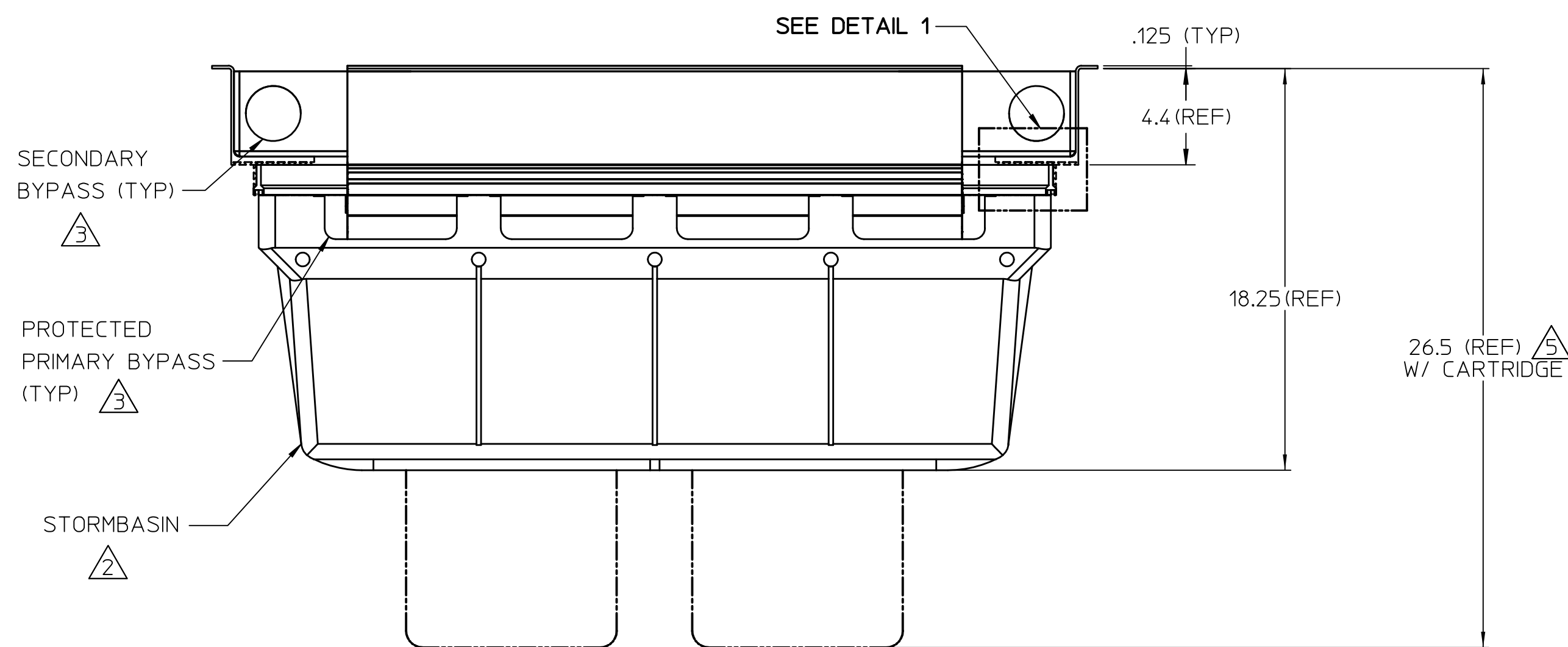
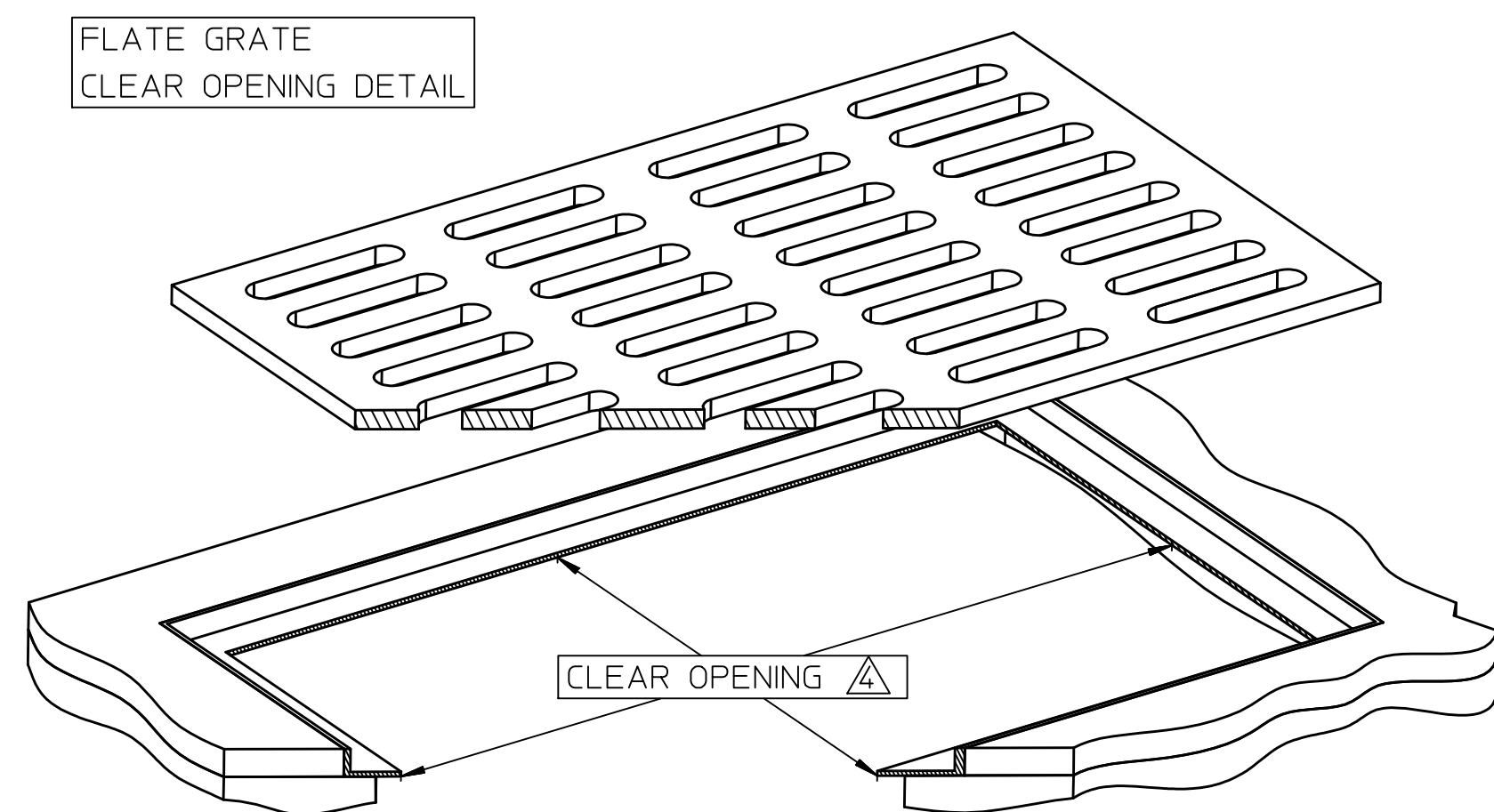

DOVETAIL ADJUSTMENT FEATURE
(TYPICAL EACH FLANGE)

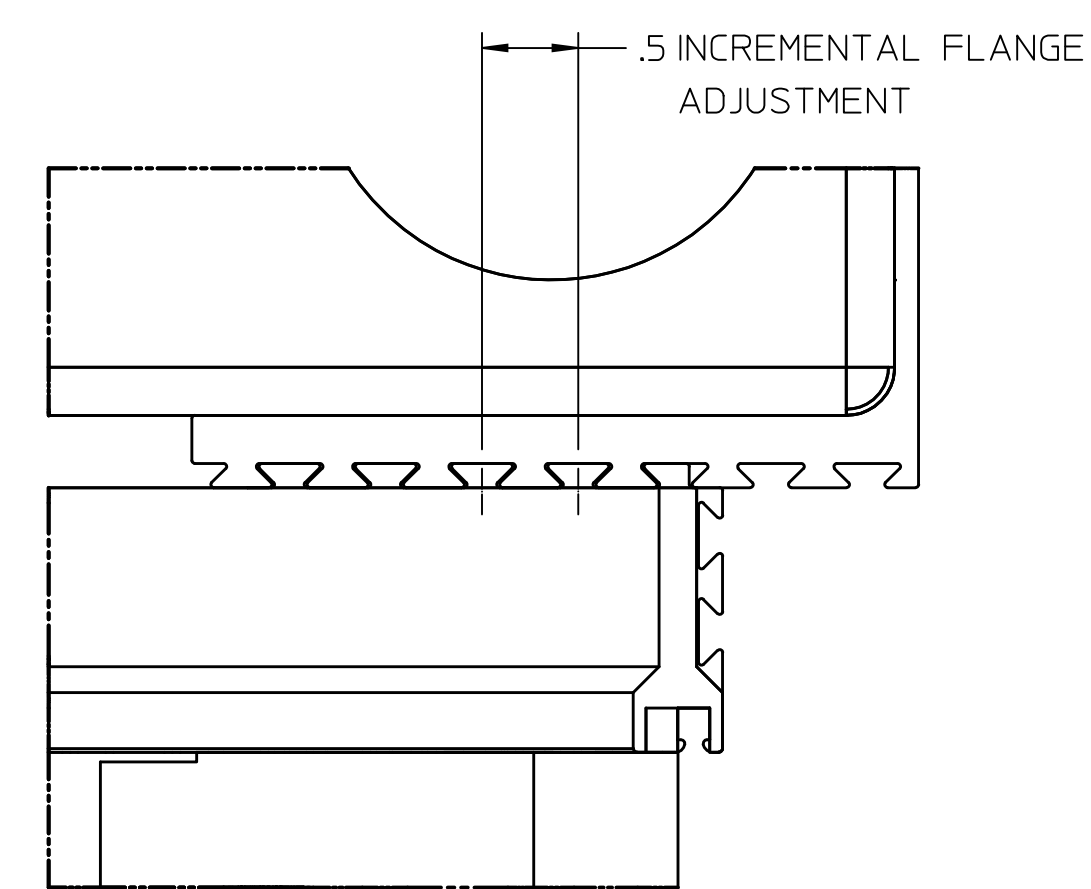

DETAIL 1
SCALE 1:1

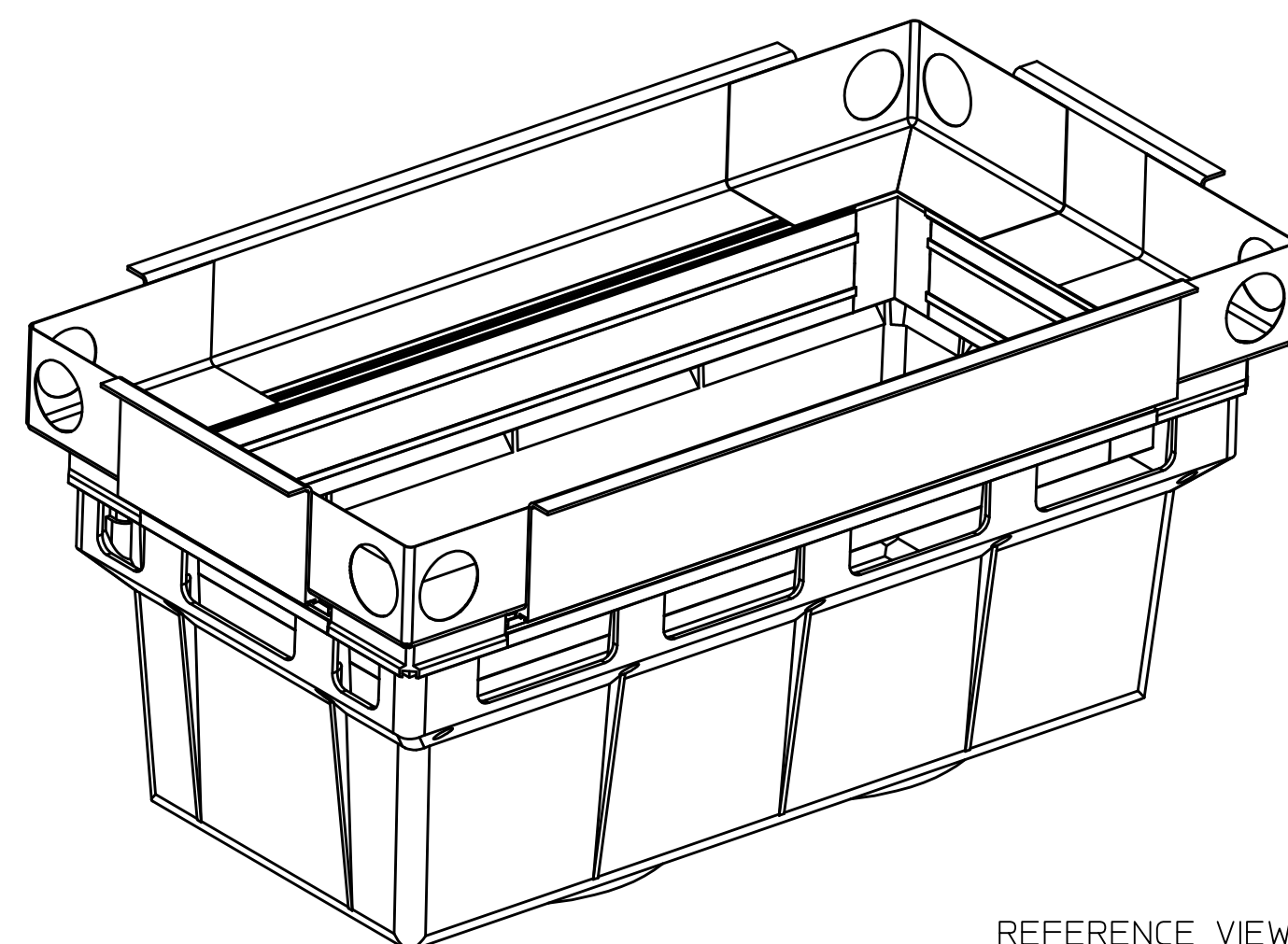

REFERENCE VIEW
NOT TO SCALE

NO	QTY	PART NUMBER	DESCRIPTION	REMARKS
UNLESS OTHERWISE SPECIFIED: TOLERANCES: DEC .00 + .01, DEC .000 + .005, FRACT: 1/16, ANGLE: ± 2°, Rg FINISH: 125/				
REMOVE ALL BURRS				
BREAK SHARP EDGES .002 - .020				
FILLETS .020 MAX				
DIMENSIONS ARE IN INCHES AND INCLUDE CHEMICALLY APPLIED OR PLATED FINISHES				
DO NOT SCALE THIS DRAWING				
MATERIAL			SEE NOTES	
MODEL LINK			9730-3C_ASSY	
APPROVALS		DATE	BILL OF MATERIALS	
DWN	N.NEUWIRTH	04/27/06	STORMBASIN, 19X37 CS	
CHKR	R.MARSTON	5/18/11	TITLE	
ENGR	J. PETERS	04/27/06	APVD	
FABCO INDUSTRIES, INC. 66 CENTRAL AVENUE FARMINGDALE, NY 11735 WWW.FABCO-INDUSTRIES.COM			SIZE	REV
D	1P8A4	9730-3C-000	CAGE CODE	C
SCALE 3/16			WT	SHEET 1 OF 1

